



GEISER INOX - MASTER INOX
the stainless steel solution!

*Chromium-nickel-molibdenum **STAINLESS STEEL**, highly resistant to pitting caused by halogen elements such as the chlorine present in drinking water, is the material used to manufacture all of the models in our "GEISER INOX" and "MASTER INOX" series.*

HYGIENIC MATERIAL: Easy to clean, it allows the use of very energetic washing and disinfecting means (e.g. anti-legionella treatments) without undergoing any changes. In DHW tanks made of stainless steel there is no accumulation of residues from sacrificial anodes because the tanks do not require cathodic protection in normal working conditions.

FOOD GRADE: Stainless steel is a non-toxic material that is commonly used in the food industry. In hygiene tests it is on a par with glass and porcelain and is thus considered ideal for use in the manufacture of tanks intended for the production and storage of domestic hot water.

MAXIMUM WORKING TEMPERATURE: It withstands the maximum DHW storage temperatures handled by this type of facilities (90°C) without undergoing any change.

LONG SERVICE LIFE: Amongst the stainless steels used for these products, **AISI 316 L stainless steel** has one of the highest levels of corrosion resistance. By way of example AISI 316 L stainless steel withstands twice as much dissolved chloride in water content than AISI 304 L steel in the same working conditions.

Cathodic protection is not required. The "GEISER and MASTER INOX" series of storage tanks do not require cathodic protection in normal conditions of use for drinking water (European Directive 98/83/CE). In the case of water which is particularly aggressive due to its chemical composition, the storage tanks supplied with lapesa correx-up permanent, maintenance-free cathodic protection.

High mechanical strength: The stainless steel withstands the mechanical stress caused by sudden fluctuations in pressure, water hammer effects of pumps, etc. without any problems or risk of damage.

EXCEPTIONAL PRODUCT QUALITY: The best-kept secret. The process employed in the manufacture of our stainless steel storage tanks is the key to their success as products of proven quality. The special welding procedures used in their manufacture and the subsequent pickling and passivation of metal surfaces, which is subject to strict quality controls, endows our products with a quality that puts them at the very highest market level. This level of quality is underpinned by our products' worldwide presence for more than 30 years.

OPTIMIZED DESIGN. BEST VALUE FOR MONEY: Design and features. The wide range of models in

our **"GEISER INOX and MASTER INOX"** series, leverages the many design options that stainless steel affords, endowing our products with the best performance features. Excellent product value-for-money comes from optimizing the design and the manufacturing process for each model.

Double-wall models with electric heating incorporated in the primary heating circuit, maintenance-free, specific high-performance models to ensure the best possible use of **RENEWABLE ENERGIES**, models for low-temperature, mixed, communal, individual or battery installations are only some of the possibilities provided by the variety of designs in our range.

The level of quality of a stainless steel tank mainly depends on the quality and execution of the manufacturing processes, well as on the design of the storage tank and the quality of the stainless steel used. The success of lapesa products is closely linked to the combination of these three aspects



APPLICABLE DIRECTIVES AND STANDARDS:

Directive 2014/68/UE: European Pressure Equipment Directive.

Royal Decree 865/2003 establishing hygiene-health criteria for the prevention and control of Legionnaires' disease.

Regulation on thermal installations in buildings (RITE) and its accompanying technical instructions.

UNE 100030:2005 IN STANDARD: Guide for the prevention and control of the proliferation and dissemination of legionella in installations.

UNE 112076:2004 IN STANDARD: Prevention of corrosion in water circuits.

APPLICATIONS

GEISER INOX

- Individual installations for the production/storage of DHW
- Single-family homes
- Gymnasiums and sports centres
- Clinics and hospitals
- Laboratories
- Restaurants, hotels, bars
- Laundries
- Schools and universities
- Solar and other renewable energy installations
- DHW centralized systems (battery installation)

MASTER INOX

- Individual production/storage installations with large DHW consumptions
- Collective housing
- Gymnasiums and sports centres
- Clinics and hospitals
- Laboratories
- Restaurants, cafeterias, bars
- Hotels
- Laundries
- Schools and universities
- Solar and other renewable energy installations
- Industrial installations (individual or battery installation)
- Large DHW consumptions (individual or battery installation)
- Centralized DHW systems in buildings (individual or battery installation)





GEISER INOX - STAINLESS STEEL

DOUBLE WALL models - nothing but advantages!

The water contained in the surrounding tank or primary tank is heated by an external energy source (boiler, heat pump, solar collectors, etc.) that passes through this vessel and transmits its thermal energy to the water contained in the inner tank or DHW storage tank.



DOUBLE-WALL TANKS: This is the star product of the "GEISER INOX" series thanks its many advantages over conventional DHW production systems.

The DOUBLE-WALL system basically consists of a combination of two tanks, one inside the other. DHW production takes place by the exchange of heat from the external or primary tank to the internal or secondary tank (DHW), throughout the whole of the tank's surface.

The water contained in the surrounding tank or primary tank is heated by an external energy source (boiler, heat pump, solar collectors, etc.) that passes through this vessel and transmits its thermal energy to the water contained in the inner tank or DHW storage tank.

DHW PRODUCTION/STORAGE TANKS GEISER INOX - **DOUBLE WALL**

lapesa

LONG-LASTING PRODUCT: Nickel-chromium-molybdenum **STAINLESS STEEL** DHW storage tank, highly resistant to pitting caused by halogen elements such as chlorine in drinking water. This is the material used to manufacture all of the models in our "GEISER INOX" series.

SELF-CLEANING EFFECT: Corrugated design of the DHW storage tank, in constant vertical movement depending on the fluctuations in the internal pressure, which helps to detach any limescale from the walls.

ANTI LEGIONELLA DESIGN: Totally uniform DHW storage temperature, with no cold zones inside the storage tank. The surround heating of DHW produces a uniform water storage temperature throughout the whole of the tank, which in turn allows it to be used to its full capacity.

MAINTENANCE-FREE: DHW tank without any internal heat exchange elements. It does not require cathodic protection in normal drinking water conditions. The models with electric heating have the heating element in the primary circuit so there is no risk of corrosion or lime scale.

LARGE DHW PRODUCTION CAPACITY: The heat exchange area is that of the total surface area of the DHW storage tank.

MAXIMUM STORAGE CAPACITY: Extra thick, rigid, PU mould-injected insulation that minimizes heat losses of stored DHW (see HEAT INSULATION chapter, page: 41)

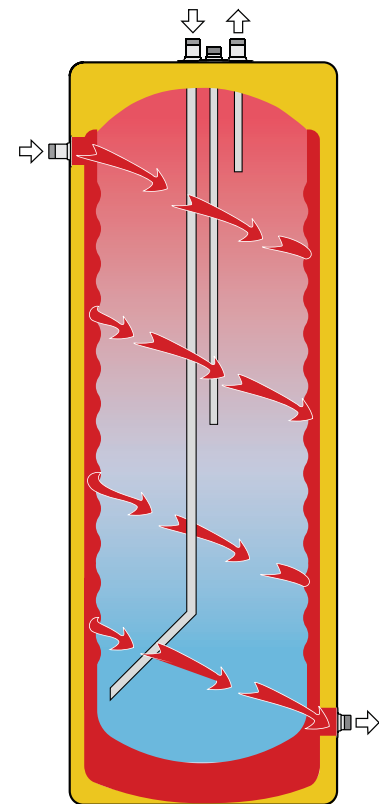

DOUBLE WALL TANKS HEATING SYSTEM



FEATURES COMMON TO ALL "DOUBLE-WALL GEISER INOX" MODELS:

- DHW storage tanks in **AISI 316 L stainless steel**
- DHW capacities: **60, 100, 150, 200, 300 and 500 litres**
- Maximum working pressure of DHW storage tank: **8 bar** (10 bar optional)
- Maximum working temperature of DHW storage tank: **90 °C**
- Maximum working pressure of surrounding tank (primary circuit): **3 bar**
- Maximum working temperature of surrounding tank (primary circuit): **110 °C**
- Thermal insulation: **Rigid, mould-injected PU** (CFC/HCFC-free, 0.025 W/m²K)
- **VERTICAL** or **HORIZONTAL** installation. Up to 150 litres, ready for **WALL MOUNTING** (except TS models)

GEISER INOX "S"

DOUBLE-WALL storage tank for the production of DHW by heat exchange between the surrounding tank (primary circuit) and the internal tank (DHW), via an external energy source (boiler, solar panels, heat pump, etc.).

Finish: RAL 9016 white external lining and RAL 7021 grey cover.

For VERTICAL or HORIZONTAL installation.

Designed for wall mounting, up to GX6 S190 model.

EQUIPMENT:

DHW thermometer on top cover. Brackets for wall mounting, up to GX6 S190 model.

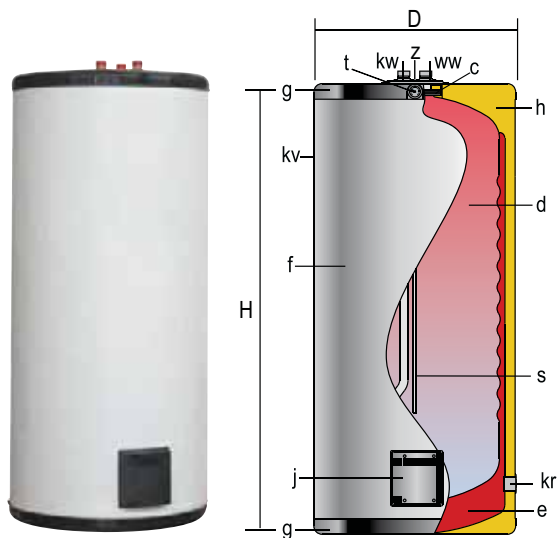

c - inspection hole
d - DHW tank
e - heating chamber
f - external lining
g - cover
h - thermal insulation
j - side hole
s - probe tube for sensors
t - thermometer

GENERAL CHARACTERISTICS		GX6 S90	GX6 S130	GX6 S190	GX6 S260	GX6 S400	GX6 S600
Total capacity	l.	82	130	191	256	365	608
DHW capacity	l.	60	100	150	200	300	500
Primary HW capacity	l.	22	30	41	56	65	108
D: external diameter	mm.	480	480	620	620	620	770
H: overall height	mm.	750	1155	985	1240	1725	1730
kw: cold water inlet / drain	" GAS/M	3/4	3/4	3/4	3/4	1	1
ww: DHW outlet	" GAS/M	3/4	3/4	3/4	3/4	1	1
z: Recirculation	" GAS/M	3/4	3/4	3/4	3/4	1	1
kv: primary input	" GAS/F	1	1	1	1	1	1 1/2
kr: primary return	" GAS/F	1	1	1	1	1	1 1/2
Heat exchange surface	m ²	0,8	1,2	1,2	1,6	2,4	3
Empty weight (approx.)	Kg	34	50	63	76	105	149

DHW PRODUCTION/STORAGE TANKS

GEISER INOX - **DOUBLE WALL**

GEISER INOX "TS"

DOUBLE-WALL storage tank for the production of DHW by heat exchange between the surrounding tank (primary circuit) and the internal tank (DHW), via an external energy source (boiler, solar panels, heat pump, etc.). Specifically designed for **HORIZONTAL INSTALLATION**.

Finish: RAL 9016 white external lining and black covers.

Able to withstand the weight of a boiler of up to 700 kg on top.

EQUIPMENT:

Thermometer & DHW regulation thermostat on front cover.

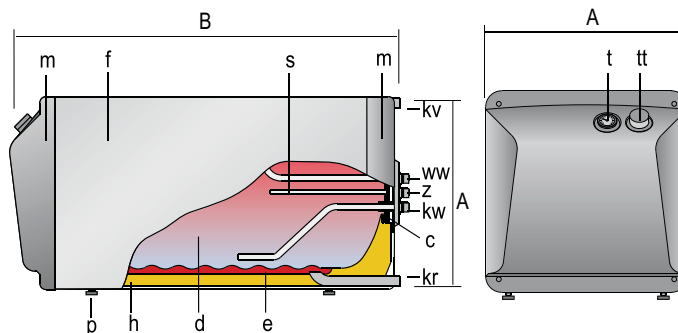

GENERAL CHARACTERISTICS		GX6 TS180	GX6 TS240
Total capacity	l.	175	233
DHW capacity	l.	150	200
Primary HW capacity	l.	25	33
A: height / width	mm.	630	630
B: length	mm.	1.000	1.225
kw: cold water inlet / drain	" GAS/M	3/4	3/4
ww: DHW outlet	" GAS/M	3/4	3/4
z: recirculation	" GAS/M	3/4	3/4
kv: primary input	" GAS/F	1	1
kr: primary return	" GAS/F	1	1
Heat exchange surface	m ²	1,2	1,6
Empty weight (approx.)	Kg	66	85

- c - inspection hole
- d - DHW tank
- e - heating chamber
- f - external lining
- h - thermal insulation
- m - side covers
- p - leveling feet
- s - probe tube for sensors
- t - thermometer
- tt - thermostat

GEISER INOX "D"

DOUBLE-WALL storage tank for the production of DHW by means of heat exchange between the surrounding tank (primary circuit) and the internal tank (DHW), via an external energy source (boiler, solar panels, heat pump, etc.).

Equipped with side hole in primary circuit for **optional incorporation of electric heating element**.

Finish: RAL 9016 white external lining and RAL 7021 grey cover.

For VERTICAL or HORIZONTAL installation (under request, see page 18)

(except TS models)

Designed for wall mounting, up to GX6 D190 model.

EQUIPMENT:

"K" control panel, wired and mounted, with thermometer, dual safety and control thermostat, winter-summer switch and LEDs.

OPTIONAL: "KP1" control panel with analog time switch for electric heating.

Brackets for wall mounting, up to model GX6 D190.

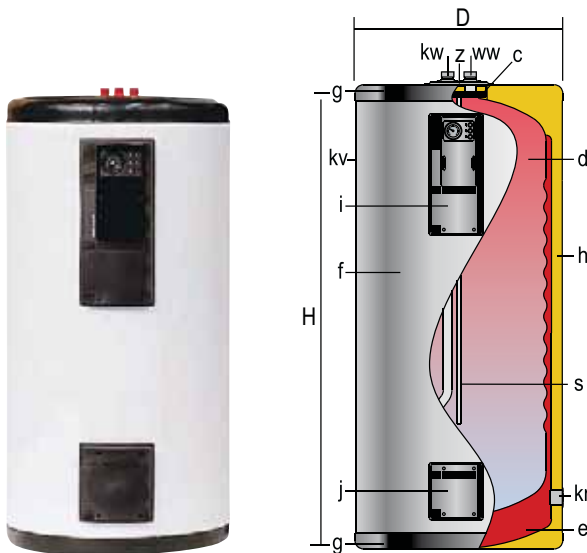

- c - inspection hole
- d - DHW tank
- e - heating chamber
- f - external lining
- g - cover
- h - thermal insulation
- i - control panel
- j - side hole
- s - probe tube for sensors
- t - thermometer

GENERAL CHARACTERISTICS		GX6 D90	GX6 D130	GX6 D190	GX6 D260	GX6 D400	GX6 D600
Total capacity	l.	82	130	191	256	365	608
DHW capacity	l.	60	100	150	200	300	500
Primary HW capacity	l.	22	30	41	56	65	108
D: external diameter	mm.	480	480	620	620	620	770
H: overall height	mm.	750	1155	985	1240	1725	1730
kw: cold water inlet / drain	" GAS/M	3/4	3/4	3/4	3/4	1	1
ww: DHW outlet	" GAS/M	3/4	3/4	3/4	3/4	1	1
z: Recirculation	" GAS/M	3/4	3/4	3/4	3/4	1	1
kv: primary input	" GAS/F	1	1	1	1	1	1 1/2
kr: primary return	" GAS/F	1	1	1	1	1	1 1/2
Heat exchange surface	m ²	0,8	1,2	1,2	1,6	2,4	3
Control panel	model	K	K	K	K	K	K
Empty weight (approx.)	Kg	36	52	65	78	107	151

DHW PRODUCTION/STORAGE TANKS

GEISER INOX - DOUBLE WALL

GEISER INOX "DE"

DOUBLE-WALL storage tank for the production of DHW by means of heat exchange between the surrounding tank (primary circuit) and the internal tank (DHW), via an external energy source (boiler, solar panels, heat pump, etc.). Equipped with side threaded connection in primary circuit for **optional incorporation of an "RI"-type THREADED electric heating element**.

Finish: RAL 9016 white external lining and RAL 7021 grey cover.

For VERTICAL or HORIZONTAL installation (under request, see page 18)

Designed for wall mounting, up to GX6 DE190 model.

EQUIPMENT:

"K" control panel, wired and mounted, with thermometer, dual safety and control thermostat, winter-summer switch and LEDs.

OPTIONAL: "KP1" control panel with analog time switch for electric heating.

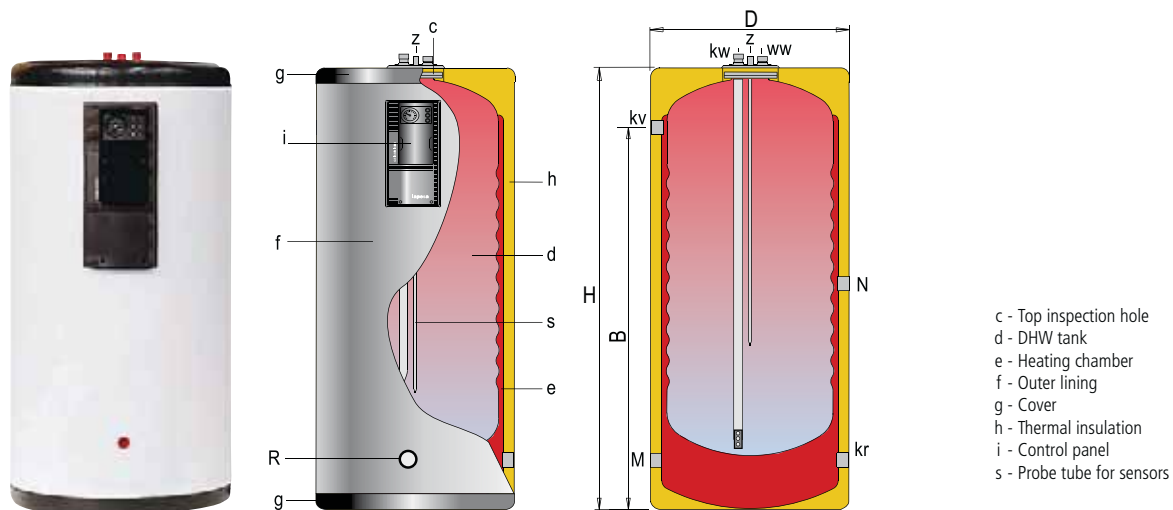

- c - Top inspection hole
- d - DHW tank
- e - Heating chamber
- f - Outer lining
- g - Cover
- h - Thermal insulation
- i - Control panel
- s - Probe tube for sensors

GENERAL CHARACTERISTICS		GX6 DE140	GX6 DE180	GX6 DE215	GX6 DE260	GX6 DE400	GX6 DE600	GX6 DE1000
Total capacity	l.	138	176	214	252	365	608	955
DHW capacity	l.	92	127	161	196	265	433	712
Primary HW capacity	l.	46	49	53	56	100	175	243
D: external diameter	mm.	560	560	560	560	620	770	950*
H: overall height	mm.	1030	1280	1530	1780	1725	1730	2250
kw: cold water inlet / drain	" GAS/M	3/4	3/4	3/4	3/4	1	1	1
ww: DHW outlet	" GAS/M	3/4	3/4	3/4	3/4	1	1	1
z: Recirculation	" GAS/M	3/4	3/4	3/4	3/4	1	1	1
kv: primary input	" GAS/F	1	1	1	1	1 1/2	1 1/2	1 1/2
kr: primary return	" GAS/F	1	1	1	1	1 1/2	1 1/2	1 1/2
R: connection for electric heating element	" GAS/F	2	2	2	2	2	2	2
N: primary side connection	" GAS/F		1	1	1	1 1/2	1 1/2	1 1/2
M: primary side connection	" GAS/F	1	1	1	1	1 1/2	1 1/2	1 1/2
Heat exchange surface	m ²	0,9	1,2	1,6	1,9	2,2	2,8	4
Control panel	model	K	K	K	K	K	K	K
Empty weight (approx.)	Kg	50	67	90	97	106	150	239

(*) Insulation system allows passing through 800 mm wide doors.

GEISER INOX "DEC"

DOUBLE-WALL storage tank for the production of DHW by means of heat exchange between the surrounding tank (primary circuit) and the internal tank (DHW), via an external energy source (boiler, solar panels, heat pump, etc.).

Equipped with side hole in primary circuit, with **factory-mounted electric heating element**.

Finish: RAL 9016 white external lining and RAL 7021 grey cover.

EQUIPMENT:

Full electric heating unit, factory-mounted and wired, comprising electric heating element and "K" control panel, with thermometer, dual safety and control thermostat, winter-summer switch and LEDs.

Brackets for wall mounting, up to model GX6 DEC190.

OPTIONAL: "KP1" control panel with analog time switch for electric heating.

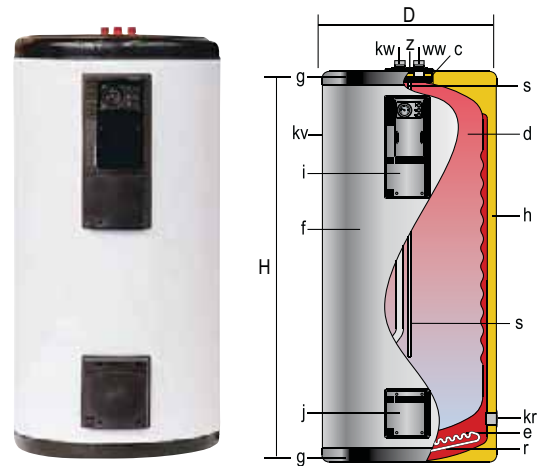

c - Inspection hole
d - DHW tank
e - Heating chamber
f - External lining

g - Cover
h - Thermal insulation
i - Control panel
j - Side hole

s - Probe tube for sensors
r - Electric heating element



GENERAL CHARACTERISTICS		GX6 DEC90	GX6 DEC130	GX6 DEC190	GX6 DEC260	GX6 DEC400	GX6 DEC600
Total capacity	l.	82	130	191	256	365	608
DHW capacity	l.	60	100	150	200	300	500
Primary HW capacity	l.	22	30	41	56	65	108
D: external diameter	mm.	480	480	620	620	620	770
H: overall height	mm.	750	1155	985	1240	1725	1730
kw: cold water inlet / drain	" GAS/M	3/4	3/4	3/4	3/4	1	1
ww: DHW outlet	" GAS/M	3/4	3/4	3/4	3/4	1	1
z: Recirculation	" GAS/M	3/4	3/4	3/4	3/4	1	1
kv: primary input	" GAS/F	1	1	1	1	1	1 1/2
kr: primary return	" GAS/F	1	1	1	1	1	1 1/2
Heat exchange surface	m ²	0,8	1,2	1,2	1,6	2,4	3
Control panel	model	K	K	K	K	K	K
Electric heating element (factory mounted)	kW	1,5	2,2	2,2	2,5	2,5	4,5
Empty weight (approx.)	Kg	37	53	67	80	109	153

WALL INSTALLATION: Double wall "GEISER INOX" models up to 190 litres total capacity can be WALL-MOUNTED. The necessary anchors are supplied with the tanks (see installation and mounting instructions).

VERTICAL POSITION: All double wall "GEISER INOX" tanks are supplied ready to be installed in VERTICAL position, with the hydraulic connections of their inner (DHW) tank on the top flange.

HORIZONTAL POSITION*: All double wall "GEISER INOX" tanks can be installed in HORIZONTAL position, with a special plate for the hydraulic connections of the inner (DHW) tank mounted on factory upon request.

The specific type of horizontal installation must be chosen, either "HORIZONTAL LEFT" or "HORIZONTAL RIGHT", according to the position of the hydraulic connections of the inner (DHW) tank.

ELECTRIC HEATING IN HORIZONTAL INSTALLATION:

The electric heating elements for HORIZONTAL installation must be ordered specifically according to the tank orientation:

- Electric heating element RC..I for horizontal left tank orientation.
- Electric heating element RC..D for horizontal right tank orientation.

For VERTICAL installations, both types of electric heating elements are valid.

*If the decision for installing a tank in horizontal position occurs after the reception of a standard model, a specific KIT of "plate with DHW hydraulic connections for horizontal installation" can be supplied, and installed in tank on site.

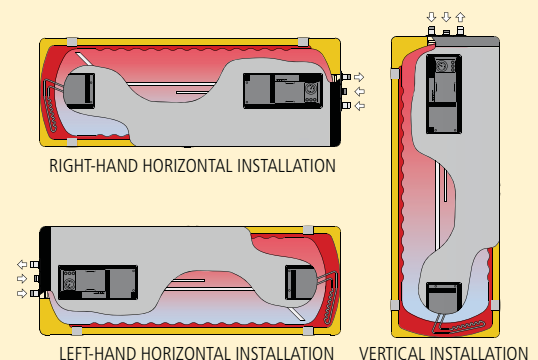

nothing but advantages!

Models DOUBLE WALL

- STAINLESS STEEL STORAGE TANK
- LARGE DHW PRODUCTION CAPACITY
- SELF-CLEANING EFFECT
- ANTI-LEGIONELLA DESIGN
- MAXIMUM STORAGE CAPACITY
- MAINTENANCE-FREE

